



OUR GLOBAL
COMPETENCE
CENTRES

 APOLLO DISPLAY
TECHNOLOGIES



 DISTEC



 DISPLAY
TECHNOLOGY



Datasheet

Distec

Frozen-Screen Detector IF444

Frozen Screen detection device

ZU-02-512

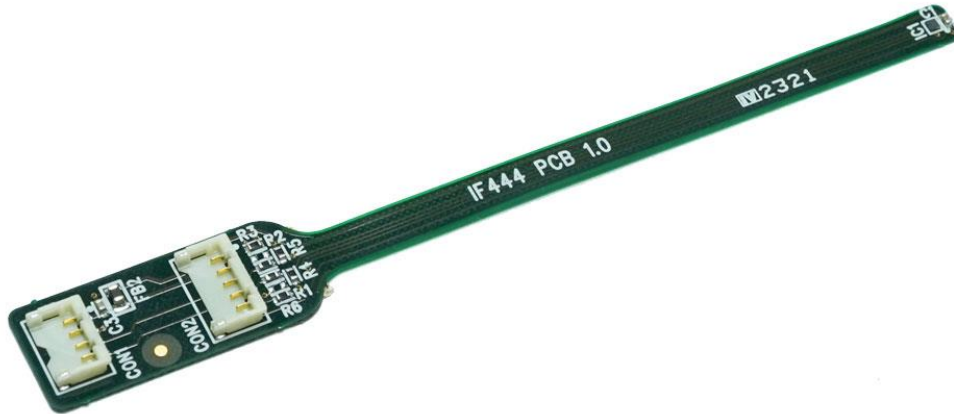

Version 1.3

21.07.2021

The information contained in this document has been carefully researched and is, to the best of our knowledge, accurate. However, we assume no liability for any product failures or damages, immediate or consequential, resulting from the use of the information provided herein. Our products are not intended for use in systems in which failures of product could result in personal injury. All trademarks mentioned herein are property of their respective owners. All specifications are subject to change without notice.

Table of Contents

1	Revision History	4
2	Overview	5
3	General Features	5
4	Absolute Maximum Ratings	5
5	Electrical Specification	6
6	Mechanical Specification	6
7	Connector Overview	6
8	Controller devices	7
9	Firmware / Software	7
9.1	Firmware	7
9.2	Software	9
9.3	Detected Error Cases	9

1 Revision History

Date	Rev.No.	Description	Page
11.03.2021	1.0	Initial version	All
15.03.2021	1.1	Changed Min. Storage and Operating Temperature Removed Red printed description	5 5, 7
17.06.2021	1.2	Changed pinning of CON1 & CON2 so it fits to the schematic	6, 7
21.07.2021	1.3	Derived Datasheet from Target Specification	All

2 Overview

The Frozen-Screen Detector is the key hardware component in the system (Frozen-Screen Detection System) that detects if the contents displayed on a screen are being updated. It is based on the light sensor OPT3006YMFR that is mounted on a flexible PCB and directed towards the monitored screen. The sensor measures changes in brightness of the monitored display and sends the information over the I2C to a controller device. Additionally, the sensor can automatically output an interrupt signal if the brightness thresholds are crossed. The controller device (LCD Controller or External Controller Unit) assesses the signal and indicates an error state to the user if the brightness does not change anymore.

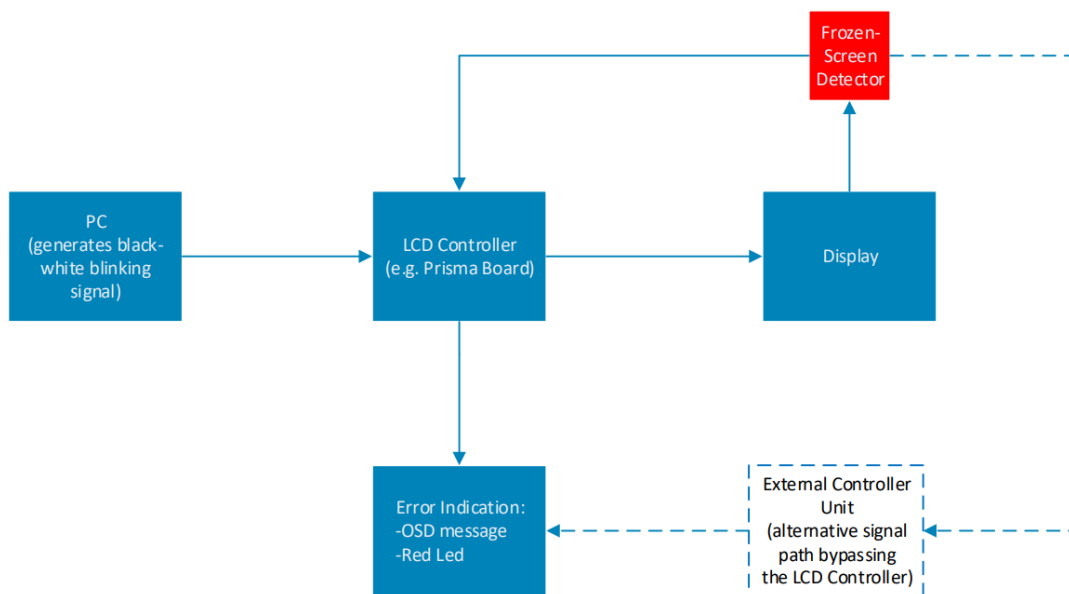

3 General Features

- Power Supply: 1.6 – 3.6 V
- Human-Eye-Like perception: rejects more than 99% of the IR light
- Wide Lux Measurement Range: 0.01 lux to 83k lux
- IC Package that allows direct placement on a display

4 Absolute Maximum Ratings

Item	Symbol	Min.	Max.	Unit	Note
Supply Voltage	V_{IN}	-0.5	6	VDC	1
Storage Temperature	T_{ST}	-25	+85	°C	1
Operating Temperature	T_{OP}	-25	+85	°C	1

Note (1): Permanent damage to the device may occur if maximum values are exceeded.

5 Electrical Specification

Item	Symbol	Min.	Typ.	Max.	Unit	Remarks
Supply Voltage	V_{IN}	1.6	3.3	3.6	V	
Supply Current	I_{IN}	-	3.7	-	μA	
Serial-Clock Frequency	f_{SCL}	10	-	400	kHz	

6 Mechanical Specification

The Frozen-Screen Detector is a flexible PCB with a layer of an adhesive on the bottom side to mount the device reliably on the surface of a screen. There are no components on the bottom side.

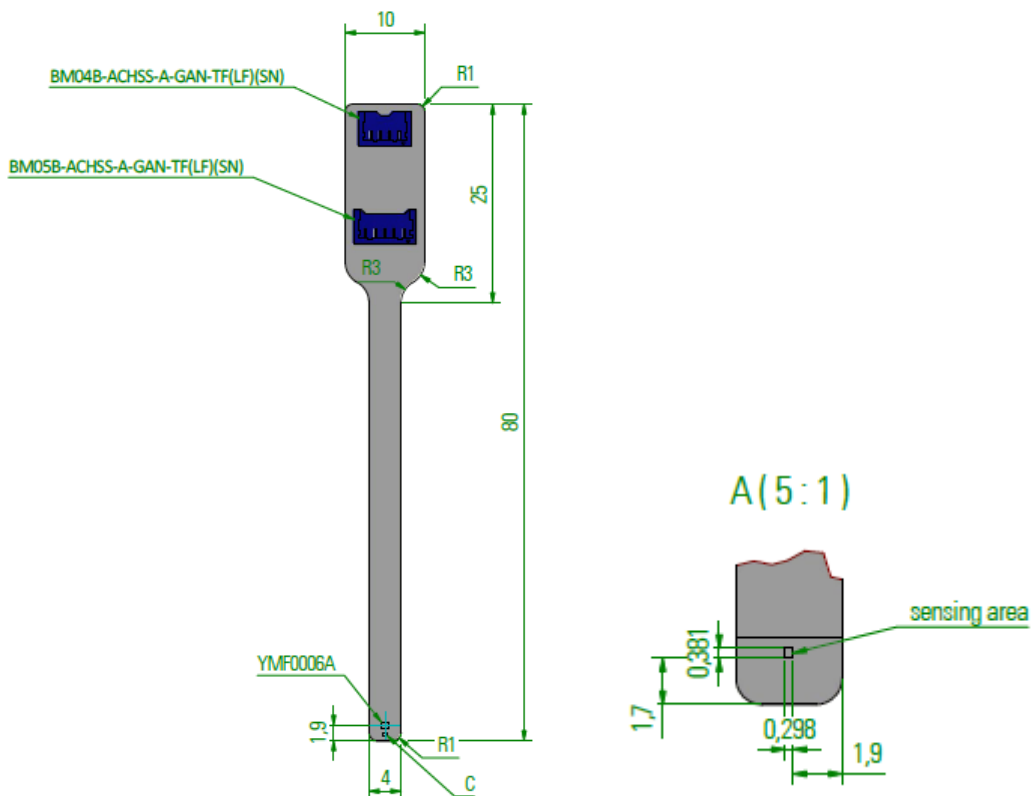

7 Connector Overview

Connector	Description	Type	Matching Part	Manufacturer
CON1	Power and I ² C Connector	BM04B-ACHSS-A-GAN-TF	ACHR-04V-A-S	JST
CON2	Power, I ² C Connector, Interrupt Output	BM05B-ACHSS-A-GAN-TF	ACHR-05V-A-S	JST

CON1: Power and I ² C Connector		
Pin	Signal	Description
1	+3.3V	Power Supply Input
2	GND	Ground
3	SCL	Serial Clock
4	SDA	Serial Data

CON2: Power and I ² C Connector with an Additional Interrupt Output		
Pin	Signal	Description
1	+3.3V	Power Supply Input
2	GND	Ground
3	SCL	Serial Clock
4	SDA	Serial Data
5	INT	Interrupt Output

8 Controller devices

The data from the Frozen-Screen Detector can be interpreted by the MStar-based Prisma boards. Alternatively, the Prisma board can be replaced with an external controller unit. The exact specification for this device will be determined in an additional document (see. IF445).

9 Firmware / Software

9.1 Firmware

The Frozen-Screen Detector works with two software components – embedded firmware and PC software. The firmware is running on the Prisma board or on an External Controller Unit.

The main task of the firmware is the detection of intensity changes that are measured by the sensor. If no changes are detected within the specified timeout period, the firmware emits various warnings (UART, GPIO, OSD menu).

The firmware can also perform a calibration to check, what is the minimum brightness that allows the display to be still operated reliably. (**available only on boards with LCD controller**)

Additionally, if the self-test feature is enabled, a display test is performed if a timeout occurs. The firmware is then able to indicate if the display is the faulty component in the system. (**available only on boards with LCD controller**)

The parameters that can be adjusted by the user are listed below.

Parameter	Description	Range	Unit
Frozen Screen On/Off	Turns the detector On or Off	On - Off	-
Timeout	The Frozen Screen Detector waits this much time, after the heartbeat signal is not present before communicating a warning message.	0 - 60	[s]
Calibration On/Off	Starts the calibration process	On - Off	-
Self-Test On/Off	Enables / Disables the self-test feature	On - Off	-
Sensor X Pos.	X position of the sensor on the screen (for calibration and self-test)	0 – Max. horizontal screen resolution	[pixel]
Sensor Y Pos.	Y position of the sensor on the screen (for calibration and self-test)	0 – Max. vertical screen resolution	[pixel]

9.2 Software

The second component of the system is the software running on the device generating the displayed content (e.g. PC, Embedded Computer). This component is not included in the Frozen Screen package. The basic function of this part of the system is to change brightness of a selected rectangular area of a screen periodically by changing its color between black and white. This way the Frozen-Screen detector receives a heartbeat signal and can detect if the screen contents are being updated. **The customer's software should have this functionality integrated into it to ensure the reliable error detection.**

The key requirements on the software can be summarized as follows:

- **The blinking feature should be integrated into the software as a Watchdog reset function. That is, the blinking signal should only be generated if the program executes properly, otherwise the generation of the signal should stop with the program.**
- **The generated black and white signal should be visible to the sensor regardless of the user applications (always on top mode).**

9.3 Detected Error Cases

The following table summarizes the errors that are detected and covered by the Frozen-Screen Detection System.

Faulty Component	Description	Detection Method Result	Error Indication Method	Remarks
Content Generating Device (e.g. PC, Embedded Computer)	Contents of the Screen are not getting updated but the old screen contents are still visible	PME-II/ External Controller Unit detects the black/white blinking PC-Signal [Failure Source: PC or Display] + Check again with PME-II generates black and white signal. 1) No detection: Display is faulty 2) Signal change detection: PC is faulty	OSD warning (PME-II) LED, GPIO, UART/USB	Primary use case
PME-II	Complete black or white screen is visible, but PME-II is not responding	PC communication [UART]	PC application detect no communication with PME-II + Light sensor Interrupt checked by PC	Error indication via LED possible if it is NOT controlled by the LCD controller
LCD Display	Complete black or white screen is visible	PME-II / External Controller Unit detects the black/white blinking PC-Signal [Failure Source: PC or Display] + Check again with PME-II generates black and white signal. 1) No detection: Display is faulty 2) Signal change detection: PC is faulty	LED, GPIO, UART/USB	

Our company network supports you worldwide with offices in Germany, Austria, Switzerland, the UK and the USA. For more information please contact:

Headquarters

Germany



FORTEC Elektronik AG

Augsburger Str. 2b
82110 Germering

Phone: +49 89 894450-0
E-Mail: info@forteca.de
Internet: www.forteca.de

Fortec Group Members

Austria



Distec GmbH Office Vienna

Nuschinggasse 12
1230 Wien

Phone: +43 1 8673492-0
E-Mail: info@distec.de
Internet: www.distec.de

Germany



Distec GmbH

Augsburger Str. 2b
82110 Germering

Phone: +49 89 894363-0
E-Mail: info@distec.de
Internet: www.distec.de

Switzerland



ALTRAC AG

Bahnhofstraße 3
5436 Würenlos

Phone: +41 44 7446111
E-Mail: info@altrac.ch
Internet: www.altrac.ch

United Kingdom



Display Technology Ltd.

Osprey House, 1 Osprey Court
Hichingbrooke Business Park
Huntingdon, Cambridgeshire, PE29 6FN

Phone: +44 1480 411600
E-Mail: info@displaytechnology.co.uk
Internet: www.displaytechnology.co.uk

USA



Apollo Display Technologies, Corp.

87 Raynor Avenue,
Unit 1 Ronkonkoma,
NY 11779

Phone: +1 631 5804360
E-Mail: info@apolloDisplays.com
Internet: www.apolloDisplays.com